

## HLSA12,5-275/4+0

- Lightning impulse current and surge arresters type T1+T2+T3.
- The products consist of varistors with big discharge ability.
- HLSA12,5 in configurations 1+1, 3+1 and HLSA12,5G are additionally combined with a gas discharge tube which ensures zero leakage current through the PE conductor.
- Suitable for objects with considerable levels of protection LPL III and LPL IV.
- Installed at the boundaries of LPZ 0 – LPZ 1 and higher zones, closest to where overhead line enters the building i.e. in the main distribution boards.
- In case of the installation of a type T1+T2+T3 in the main switchboard, it is also necessary to install type T2 and T3 in any additional distribution boards in the electrical installation.
- If the product contains two PE (or PEN) terminals, it must not be used as a PE (PEN) bridge.
- **M** indication specifies a type of construction with removable module.
- **S** indication specifies a version with remote monitoring.

Type		HLSA12,5-275/4+0
Test class according to EN 61643-11:2012 (IEC 61643-11:2011)		T1, T2, T3
System		TN-S
Number of poles		4
Rated operating AC voltage	$U_N$	230 V
Maximum continuous operating voltage AC	$U_C$	275 V
Maximum discharge current (8/20)	$I_{max}$	50 kA
Impulse discharge current for class I test (10/350)	$I_{imp}$	12.5 kA
Charge	$Q$	6.25 As
Specific energy for class I test	$W/R$	39 kJ/Ω
Total discharge current (10/350) L1+L2+L3+N->PE	$I_{Total}$	50 kA
Total discharge current (8/20) L1+L2+L3+N->PE	$I_{Total}$	200 kA
Nominal discharge current for class II test (8/20)	$I_n$	25 kA
Open circuit voltage of the combination wave generator	$U_{OC}$	6 kV
Voltage protection level at $I_n$	$U_p$	< 1.2 kV
Temporary overvoltage test (TOV) for $t_T = 5$ s	$U_T$	337 V
Temporary overvoltage test (TOV) for $t_T = 120$ min	$U_T$	440 V
Response time	$t_A$	< 25 ns
Maximal back-up fuse		160 A gL/gG
Residual current	$I_{PE}$	≤ 300 μA
Short-circuit current rating at maximum back-up fuse	$I_{SCCR}$	60 kA <sub>rms</sub>
Lightning protection zone		LPZ 0-1, LPZ 1-2, LPZ 2-3
Housing material		Polyamid PA6, UL94 V-0
Degree of protection		IP20
Operating temperature	$\theta$	-40 ÷ 70 °C
Humidity range	RH	5 ÷ 95 %
Minimum cross-section of connected Cu conductors accord. to HD 60364-5-53:2022 (doesn't apply to „V“ connection) for T1	S	6 mm <sup>2</sup> (L, N) 16 mm <sup>2</sup> (PE, PEN)

Type		HLSA12,5-275/4+0
Minimum cross-section of connected Cu conductors accord. to HD 60364-5-53:2022 (doesn't apply to „V“ connection) for T2	S	2.5 mm <sup>2</sup> (L, N) 6 mm <sup>2</sup> (PE, PEN)
Power conductor stripping length		10 mm
Clamp fastening range (solid conductor)		1.5 ÷ 25 mm <sup>2</sup>
Clamp fastening range (stranded conductor)		1.5 ÷ 16 mm <sup>2</sup>
Tightening torque		3 Nm
Installation		On DIN rail 35 mm
Modular width		4 TE
Width		70 mm
Height		90 mm
Depth		65.8 mm
Operating position		Any
Product placement environment		Internal
Signalling at the device		Optic
Importance of local signaling		OK – clear target FAULT – red target
Remote signalling		No
Pluggable version		No
Lifetime		> 100 000 h
<b>Designed according to standards</b>		
Requirements and test methods for SPDs connected to low-voltage power systems		IEC 61643-11:2011
Safety of Flammability of Plastic Materials		UL 94
<b>Application standards</b>		
Protection against lightning		IEC 62305:2010
Selection and erection of electrical equipment – Switchgear and controlgear		HD 60364-5-53:2022
Selection and application principles for SPDs connected to low-voltage power systems		CLC/TS 61643-12:2009
<b>Ordering, packaging and additional data</b>		
Mass	m	560 g
Mass (including the packaging)	m	588 g
Packaging dimensions (H x W x D)		74 x 112 x 73 mm
Packaging value	V	0.61 dm <sup>3</sup>
ETIM group		EG000021
ETIM class		EC001457
Customs tariff no.		85363010
EAN code		8590681113301
<b>Art. number</b>		<b>10 065</b>



The link in the QR code leads to the online presentation of the **HLSA12,5-275/4+0**. There, in addition to the always up-to-date data sheet, you will also find all diagrams and drawings, declarations of conformity, or 2D or 3D models and other necessary materials. For more information, visit [www.hakil.com](http://www.hakil.com)



**Application wiring diagram (installation)**

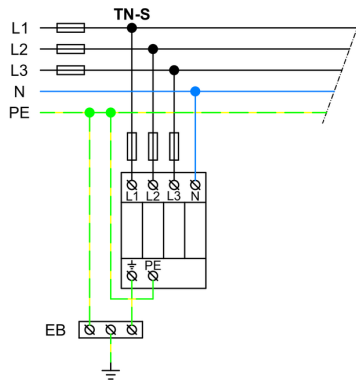

**Internal diagram**

